

WavePath 4500™ Product Brief

Wavelength Selective Switch (WSS) with Integrated Optical Channel Monitor (OCM)

Enabling the Dynamic and Reconfigurable Optical Network



Key Features

- Wide passbands
 - Maximizes cascading of transparent nodes minimizing expensive OEO signal regeneration
 - Supports up to 40Gb/data rate
- Low insertion loss
 - Minimizes amplification costs
- Hitless switching
 - No impact on established traffic
- Power control of each channel
 - Eliminates need for VOAs or DGEs
- Integrated Optical Channel Monitoring
 - Eliminates need for external OCM
 - Provides per channel power monitoring
 - Enables constant output power mode
 - Provides center wavelength monitoring and drift alarms
 - Provides wavelength connectivity (configuration) confirmation
 - Provides signal-to-noise variance
- Closed-Loop Control Systems
 - Ensures optimal performance and reliability over all operating conditions throughout its life
 - Maintains optimal ITU alignment

Capella Photonics' WavePath 4500™ is a Wavelength Selective Switch (WSS) with an Integrated Optical Channel Monitor (OCM) for Reconfigurable Optical Add/Drop Multiplexer (ROADM) and Optical Cross Connect (OXC) applications. It delivers the highest level of functional integration in an extremely compact and cost effective module.

The product, which operates effectively independent of data transmission rates and format, integrates discrete functions such as multiplexing, demultiplexing, hitless wavelength reconfiguration (allowing any incoming wavelength(s), to be directed to any output port), dynamic channel equalization, wavelength and power monitoring, channel blocking, and channel configuration verification.

Through its patented Closed-Loop Control Systems, the WavePath 4500™ maintains optimal coupling and ITU alignment over all operating conditions. The automatic compensation for environmental changes ensures reliable operation over the lifetime of the product.

The WavePath 4500™ is available as a 10 port solution, configurable to either add or drop functionality (*i.e.*, 1x9 or 9x1), and supports up to 45 channels in the C-band spaced at 100 GHz.

Applications

WavePath 4500™ in ROADM Nodes

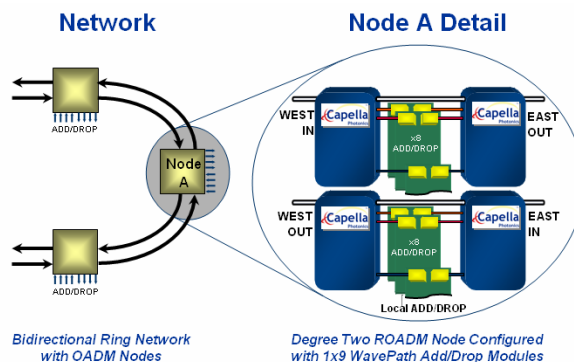

Scaling to More Drop Ports

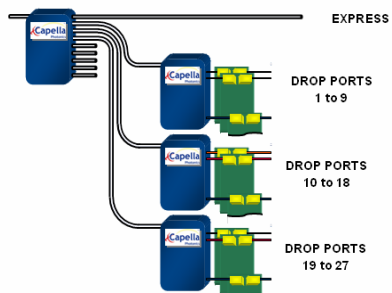

Port count can be scaled *in-service* in increments of 9 ports

Scaling to Higher Degree Nodes

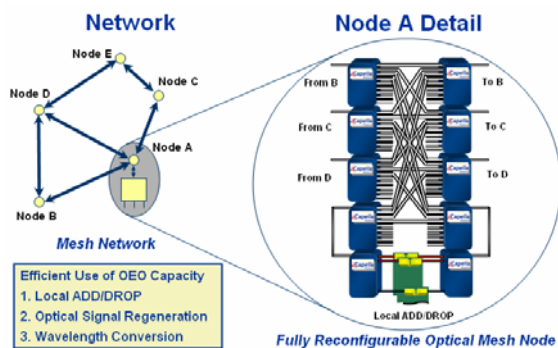

Physical Dimensions

WavePath 4500™
(Side exit Discrete fibers – SD50 pin)

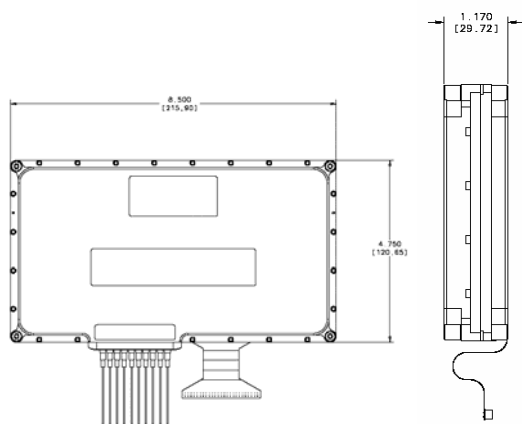
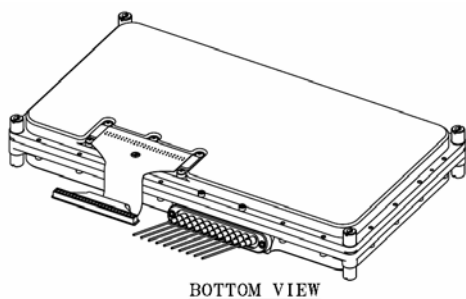
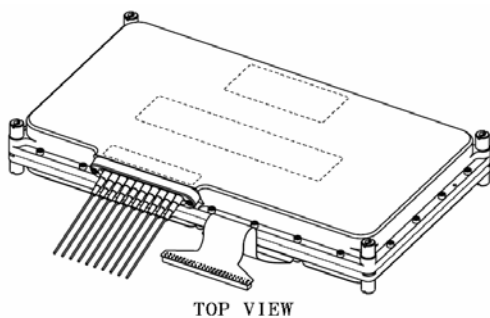

WavePath 4500™
(End exit Discrete fibers – ED80 pin)

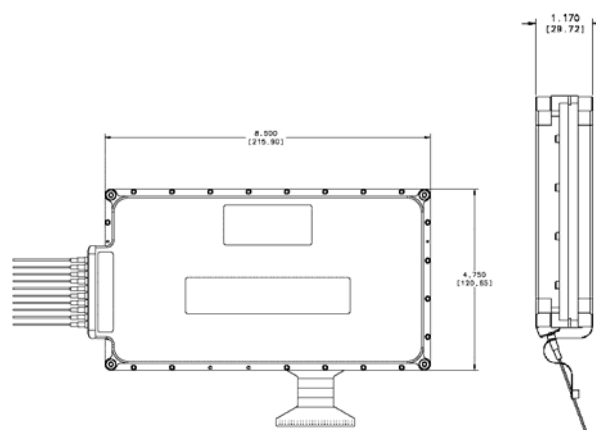
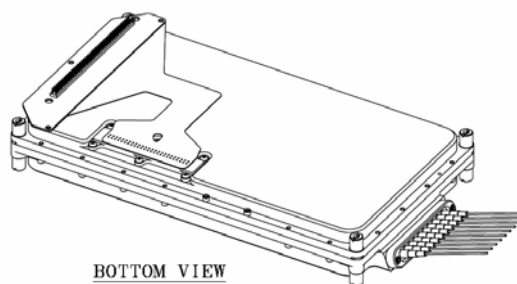
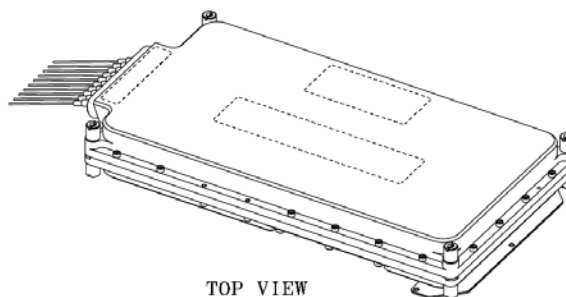

Overall Dimensions:	29.72mm x 120mm x 216mm (1.17" x 4.75" x 8.50")
Electrical Connector:	50 or 80 pin
Fiber Exit:	Side or End
Fiber Type:	Corning SMF-28 or equivalent, 0.95mm Hytrel Jacket
Fiber Length:	1m
Weight:	2.6 lbs. (1.2 kg)

Patents

This product is covered by one or more of the following U.S. Patents:

6,504,976 B1; 6,507,685 B1; RE39411; RE39397; 6,661,948 B2; RE39331; 6,695,457 B2;
6,753,960 B1; 6,760,511 B2; 6,820,988 B2; 6,804,428 B1; 6,879,750 B2; 6,909,819 B1;
7,057,796 B1; 7,164,859; 7,177,496B1; 7,209,274B2

And one or more of the following foreign patents:

ZL02810212.6 (CN); 100193 (SG); 200748 (IN); 2002255773 (AU)